

Coil Specification (at 20°C)

Coil Sensitivity	Nominal Voltage (VDC)	Nominal Current (mA)	Coil Resistance ($\Omega \pm 10\%$)	Power Consumption (W)	Pull-In Voltage (VDC)	Drop-Out Voltage (VDC)	Maximum Allowable Voltage (VDC)
GS - D	3	120	25	Abt. 0.36	75% Maximum	10% Minimum	150%
	5	71.4	70				
	6	60	100				
	9	40	225				
	12	30	400				
	24	15	1,600				
GS - T	3	66.7	45	Abt. 0.20	75% Maximum	10% Minimum	150%
	5	40	125				
	6	33.3	180				
	9	22.2	405				
	12	16.7	720				
	24	8.3	2,880				

Ordering Information:

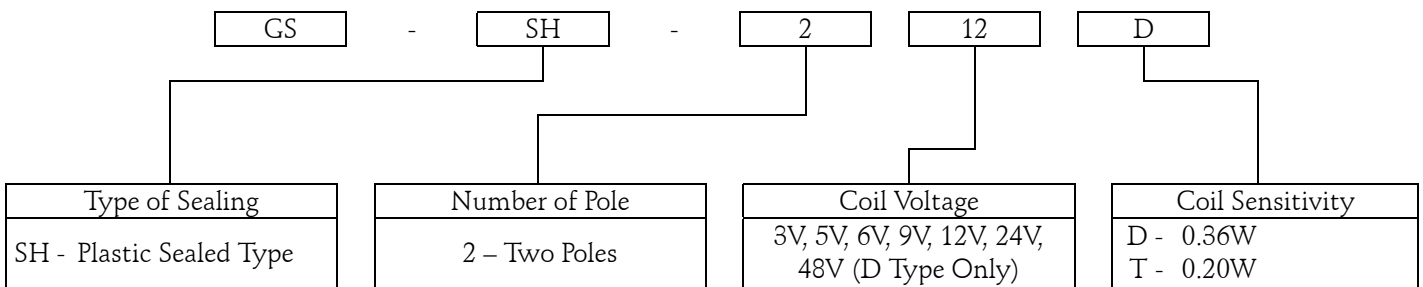

Dimension:

GS-SH

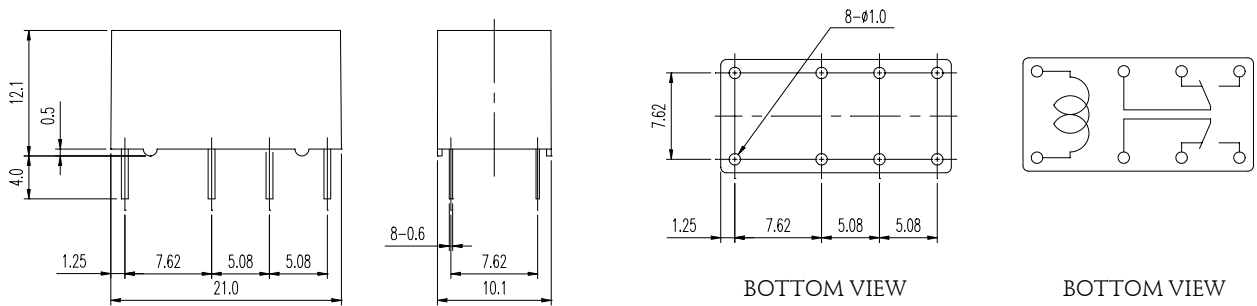

Reference Data:

